



CDVI

EN ENGLISH

FR FRANCAIS



* Refer to limited lifetime warranty conditions. / Voir conditions de garantie à vie limitée.

SD300 SD300M SD500 SD500M

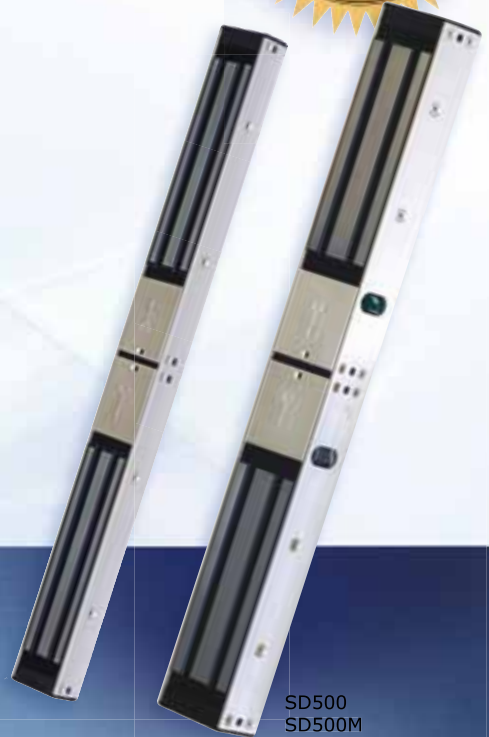

SD300
SD300M

SD500
SD500M

Double Surface Mount Electromagnets *Ventouses électromagnétiques appliques doubles*

Range: Locking Devices / **Gamme:** Verrouillage

INSTALLATION MANUAL MANUEL D'INSTALLATION

SD300 - SD300M - SD500 - SD500M

Double surface mount Electromagnetic locks

Thank you for buying our products and for the confidence you placed in our company.

1] PRODUCT PRESENTATION

- **Double magnetic locks.**
- **Surface mount.**
- **Monitored**.**
- **Holding force:** 2 x 300 or 2 x 500kg**.
- **Security rope**.**
- **High corrosion resistance.**
- **No mechanical wear.**
- **Ease of installation.**
- **Indoor use.**
- **Fail safe (Door unlocked when power off).**
- **No residual magnetism.**
- **Built-in varistor:** *Electric protection to eliminate back EMF.*

- Electromagnetic lock dimensions (L x W x D):
 - SD300 - SD300M = 496 x 45 x 26mm,
 - SD500 - SD500M = 532 x 66 x 40mm.
- Armature dimensions (l x w x d):
 - SD300 - SD300M = 185 x 38 x 11mm,
 - SD500 - SD500M = 185 x 60 x 12mm.
- Silent operation.
- Power supply: 12/24V dc.
- Power absorption:
 - 12 V DC = 1.2A,
 - 24 V DC = 620mA.

Refs	Holding force	Monitored
SD300	2 x 300kg	-
SD300M	2 x 300kg	✓
SD500	2 x 500kg	-
SD500M	2 x 500kg	✓



Recommended power supplies



ARD212



BS602



2] REMINDERS AND RECOMMENDATIONS

The function of an electromagnetic lock is to ensure the locking of an access point. This document is a guide of installation which will allow you to secure the installation according to the characteristics of the product, the site and the environmental requirements.

APPROVAL RELATIVE TO EMERGENCY EXITS:

In the case of an installation of electromagnetic lock on emergency exits, it is imperative to make sure that these exit points will be automatically free in case of fire alarm, to open in the event of a fire alarm to allow evacuation of the premises. The electromagnetic lock installed on emergency exits must be in accordance with the fire approval department (Ex: In France = NF S 61-937).

For more information, contact CDVI, the local fire officer or the safety officer responsible for the building.

* Refer to limited lifetime warranty conditions.
 ** Depending on the version.

SD300 - SD300M - SD500 - SD500M*Double surface mount Electromagnetic locks***POWER SUPPLY**

An electromagnetic lock always operates in DC current, a very low safety voltage.

The Diax® electromagnetic lock is recommended for use with power supplies manufactured by CDVI, however, other power supplies may be used on condition that they are of equivalent quality and characteristics rectified, filtered, regulated and protected by fuse in primary and secondary sectors.

MOUNTING RECOMMENDATIONS

- Define the level of security of the access.
- Determine the maximum strength of holding force to this level of security.
- Select the Diax® electromagnetic lock according to the environment, the inside, the outside, the climatic constraints, (For example: stainless steel dedicated to an outside use).
- Always install the electromagnetic lock on the secure side of the place to be secured.
- Indeed make sure that the frame and opening, receiving or supporting the electromagnetic lock, armature plate and their accessories, are solid and resistant to damage or wear over a period of time.
- Consider any bracketry required for the assembly according to the type of support receiving the electromagnetic lock and armature plate.
- Define the passage of cables to ensure the protection against the vandalism and the environmental requirements (in particular through flexible hoses of door, glands, gutters, cross cables, plastic tubes).

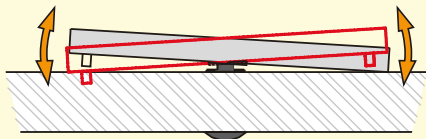
**Armature plate**

- It is vital to fix the electromagnetic lock and armature plate solidly on their supports.
- Make sure that the magnet and the armature meet evenly over their entire mating surfaces.
- The Armature plate must be able to pivot slightly about its center mounting screw to compensate for any door misalignment.

Security ropes



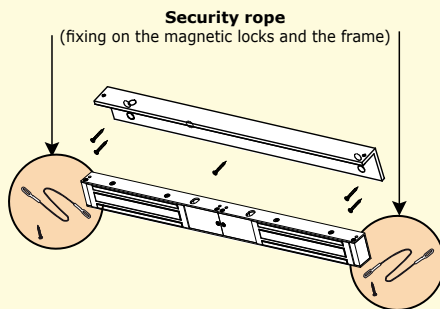













The electromagnetic lock undergoes repeated shocks and the vibration at the points of fixation on the frame (frequencies of openings / closures, attempt of opening wears closed and attempts of vandalism) which can loosen the fixing bolts/screws. To prevent the risk of the electromagnetic block from falling, install both security ropes supplied, to guarantee the safety of the users (see attached plan).

**MAINTENANCE**



The Electro magnet and armature plate have a specific treatment which strengthens the protection against wear and corrosion. These products do not require high maintenance. Nevertheless to ensure optimum performance, it is recommended to clean regularly the surfaces in contact of the electro magnet and armature plate with a cloth and non abrasive products. If traces of corrosion appear, it is recommended to clean and oil the contact surfaces. Check and tighten regularly all the fixings of the Electro magnet and ensure that while the armature is able to pivot on its mounting, the fixing bolt is not liable to loosen (we recommend thread-lock for all fixing bolts).

SD300 - SD300M - SD500 - SD500M
Double surface mount Electromagnetic locks

3] PACKAGE CONTENTS

							
Surface mount magnetic lock	Armature plate	Fixing plate	Roll pin 5x16	Steel washer	4x25 wood screw	Key 3mm	Key 5mm
1	2	1	4	4	14	1	1
							
M8x35 screw	M8x25 screw	3x8 self-tapping screw	Guide piece	Cap nut	Safety rope	Rubber washer	Installation manual
2	2	2	2	2	2	2	1

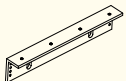
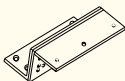
4] OPTIONAL ACCESSORIES

			
References	LD3LD5	Z3Z4Z5	AMA3 (300KG) AMA5 (500KG)
Description	L shaped bracket	Z shaped bracket	Armature housing

5] ELECTRICAL CONNECTIONS

TERMINAL BLOCK	CORRESPONDENCE	SD300 SD500	SD300M SD500M
+	12 or 24V dc	■	■
-	- 0 V	■	■
N.C	NC (Normally closed)	-	■
COM	COM	-	■
N.O	NO (Normally open)	-	■



**12V dc
Factory
setup**

The NO/NC signal only switches when the door is closed with the power to it on.

SD300 - SD300M - SD500 - SD500M
 Double surface mount Electromagnetic locks

WITH BUILT-IN PCB BOARD

SD300 - SD500

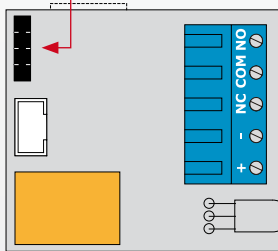
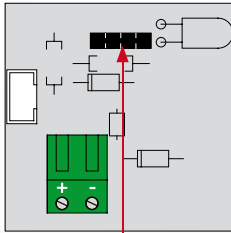

SD300M - SD500M

DIRECT CONNECTION

12V DC

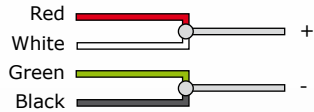

24V DC

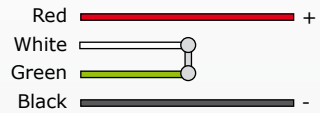

CONTACT



IMPORTANT NOTE

- Check the jumper position before connecting the lock to the input current. A wrong position could damage the lock. This type of damage is not covered by the warranty.
- Make sure that the magnet and the armature meet evenly over their entire mating surfaces.

The Armature plate must be able to pivot slightly about its center mounting screw to compensate for any door misalignment.

SD300 - SD300M - SD500 - SD500M
 Double surface mount Electromagnetic locks

6] INSTALLATION

Installation on an outward opening door (Push door)

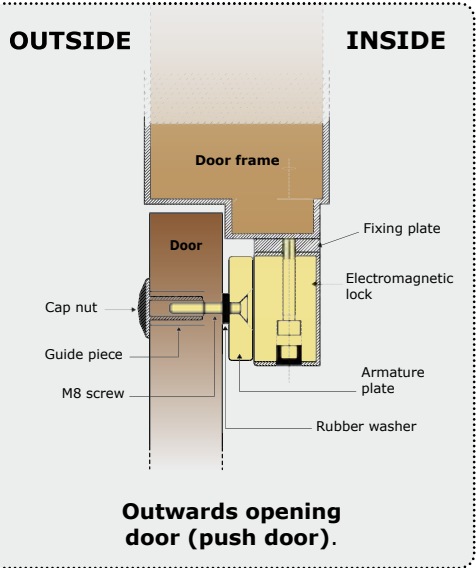
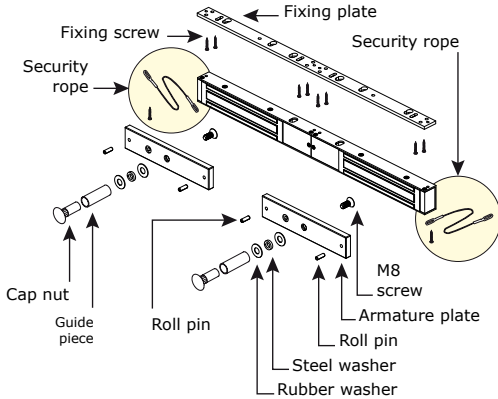

Installation on an inward opening door (Pull door)

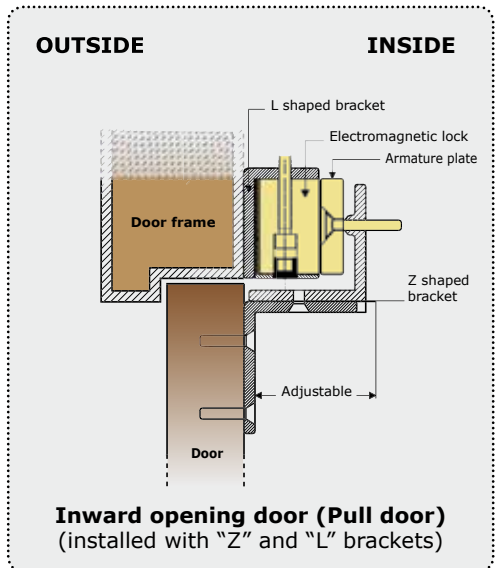
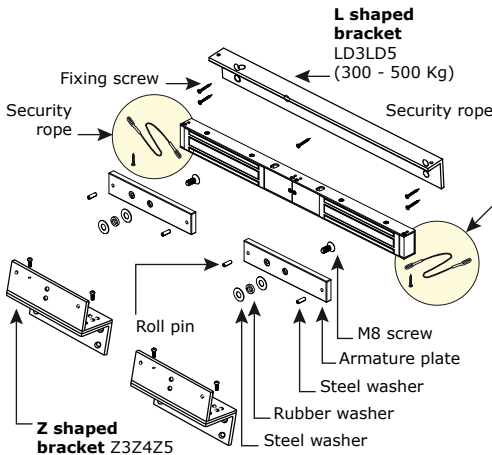

SD300 - SD300M - SD500 - SD500M
Double surface mount Electromagnetic locks

7] INSTALLATION WITH ACCESSORIES

Installation with an Armature housing

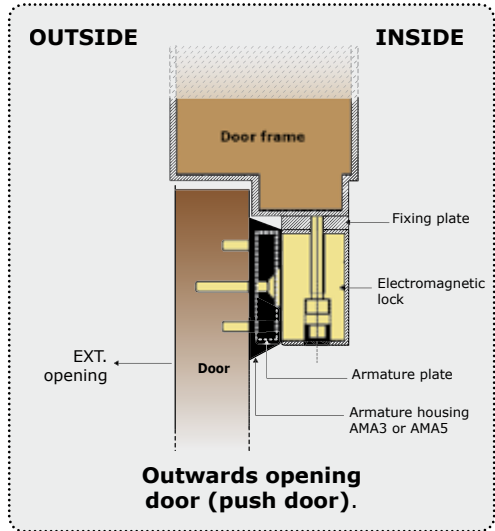
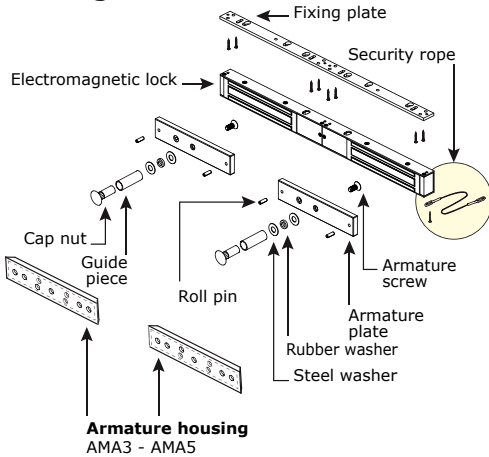

8] FAULT FINDING

PROBLEM	POSSIBLE CAUSE	SOLUTION
Door locking impossible	The lock is not receiving DC current.	<ul style="list-style-type: none"> - Check that the wires are connected to the right terminals. - Check that the power supply is compatible. - Check that the lock is connected to the circuit correctly.
Holding force reduced	The lock and the armature are not lined up with each other.	<ul style="list-style-type: none"> - Check that the lock is connected to the circuit correctly. - Check that the electromagnet and the armature are properly aligned. - Check that the contact faces are free from dirt and rust. - Check that the armature is soft mounted.
	Low voltage or armature jammed.	<ul style="list-style-type: none"> - Check that the lock is receiving the correct power supply satisfactorily. - check the tightening of the armature and the condition of the rubber.
Faulty reed switch	Voltage too low. Misalignment.	<ul style="list-style-type: none"> - Check the power supply. - Cable cross section to be determined according to the power supply and the locking. - e.g.: $2 \times 1.5\text{mm}^2 \geq 10\text{m}$.

SD300 - SD300M - SD500 - SD500M

Double surface mount Electromagnetic locks

9] LIMITED LIFETIME WARRANTY [EXTRACT]*

CDVI warrants this product to be free from defects in material and workmanship, when it has been installed in accordance with the manufacturer's instructions and has not been modified or tampered with. Only product recognized by CDVI to be defective should be returned under these warranty terms if accompanied by an RMA (Return Material Authorization Number) provided by CDVI. CDVI, at its option, shall repair or replace the defective product at CDVI premises or at any CDVI approved service center. This warranty does not cover any damage due to accident, misuse, abuse or negligence. This warranty is valid only if the product is registered, within 1 month from delivery to the final customer. To obtain full details of this warranty and to register the product to commence the "Limited Lifetime Warranty", complete the enclosed registration card and return it, either by e-mail or post, to the relevant CDVI address or completion of the on line registration at www.cdvigroup.com. Repair or replacement of the defective product is the exclusive remedy. CDVI shall not be liable for any incidental or consequential damages arising from any defect in, or malfunction of, its product. In no event the entire liability can not exceed the purchase price of the product. The CDVI local country contact details can be found on line by visiting www.cdvigroup.com or on the back cover of the installation manual.

DISCLAIMER OF WARRANTY: EXCEPT AS STATED ABOVE, CDVI MAKES NO WARRANTIES, EITHER EXPRESS OR IMPLIED, AS TO ANY MATTER WHATSOEVER, INCLUDING THE CONDITION OF ITS PRODUCTS, THE TRANSPORTATION, THEIR MERCHANTABILITY OR FITNESS FOR ANY PARTICULAR PURPOSE.

10] NOTES

.....

.....

.....

.....

.....

.....

.....

.....

.....

.....

.....

.....

.....

.....

.....

.....

.....

.....

.....

.....

.....

.....

.....

.....

.....

* Refer to complete limited lifetime warranty on [cdvigroup](http://cdvigroup.com) website.

SD300 - SD300M - SD500 - SD500M

Ventouses électromagnétiques appliques doubles

Merci pour l'achat de ce produit et pour la confiance que vous accordez à notre entreprise.

1] PRESENTATION PRODUIT

- **Ventouse double.**
- **Applique.**
- **Signal**.**
- **Force de rétention** : 2 x 300 ou 2 x 500 kg**.
- **Filin de sécurité*.**
- **Haute résistance à la corrosion.**
- **Pas d'usure mécanique.**
- **Facilité d'installation.**
- **Préconisée en intérieur.**
- **Sécurité positive**
(libère instantanément l'accès en cas de coupure de courant).
- **Pas de magnétisme résiduel.**
- **Varistance incorporée** : Protection électronique intégrée contre l'effet de self.

- Dimensions des ventouses (L x l x P) :
 - SD300 - SD300M = 496 x 45 x 26 mm,
 - SD500 - SD500M = 532 x 66 x 40 mm.
- Dimensions des contre-plaques (L x l x P) :
 - SD300 - SD300M = 185 x 38 x 11mm,
 - SD500 - SD500M = 185 x 60 x 12mm.
- Fonctionnement silencieux.
- Alimentation : 12/24 V DC.
- Consommation :
 - 12 V DC = 1,2A,
 - 24 V DC = 620mA.

Référence	Force de rétention	Signal
SD300	2 x 300 kg	-
SD300M	2 x 300 kg	Oui
SD500	2 x 500 kg	-
SD500M	2 x 500 kg	Oui

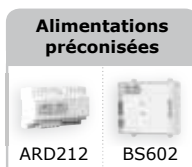

DEEE



IP42



Certification CE



RoHS

2] RAPPELS ET RECOMMANDATIONS

La fonction d'une ventouse électromagnétique est d'assurer le verrouillage d'un accès. Ce document est un guide de pose qui vous permettra de sécuriser l'installation en fonction des caractéristiques du produit, du site et des contraintes environnementales.

NORME INCENDIE RELATIVE AUX ISSUES DE SECOURS

Dans le cas d'une installation de ventouses électromagnétiques sur des issues de secours, il est impératif de s'assurer que ces accès seront automatiquement libres en cas d'alarme incendie, pour permettre une évacuation des lieux. Les ventouses électromagnétiques installées sur des issues de secours doivent impérativement être conforme à la norme incendie locale (Ex : En France = NF S 61-937).

Pour plus d'informations, rapprochez-vous de CDVI, de l'organisme certifié local ou du centre de sécurité du bâtiment.

* Voir conditions de garantie à vie limitée.

** Selon version.

SD300 - SD300M - SD500 - SD500M*Ventouses électromagnétiques appliques doubles***ALIMENTATION**

Une ventouse électromagnétique fonctionne toujours en courant continu, impérativement en très basse tension de sécurité (TBTS). Les ventouses électromagnétiques Diax® sont préconisées avec les alimentations de la gamme CDVI, toutefois, d'autres alimentations peuvent être utilisées à la condition que celles-ci présentent une qualité et des caractéristiques équivalentes, notamment redressée, filtrée, régulée, protégée par fusible en primaire et secondaire...

CONSEIL D'INSTALLATION

- Définir le niveau de sécurité de l'accès.
- Adapter la force de rétention maximum à ce niveau de sécurité.
- Sélectionner la ventouse électromagnétique Diax® en fonction de l'environnement, intérieur, extérieur, contraintes climatiques, ... (Par exemple : inox dédiée à une utilisation extérieure).
- Installer toujours la ventouse à l'intérieur du lieu à sécuriser.
- Bien s'assurer que le dormant et l'ouvrant, recevant ou supportant la ventouse, la contre-plaque et leurs accessoires, soient solides et résistants dans le temps.
- Adapter les éléments de montage en fonction du type support recevant la ventouse et la contreplaque (visserie, chevilles, accessoires,...).
- Définir le passage des câbles pour en assurer la protection contre le vandalisme et les contraintes environnementales (notamment par l'intermédiaire de flexibles de porte, presse-étoupe, goulottes, passe câbles, tubes plastiques, ...).

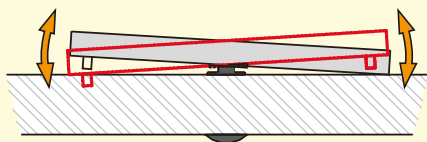
**La contre-plaque**

- Il est vital de fixer solidement la ventouse et la contreplaque sur leurs supports.
- Mettre en vis-à-vis la ventouse et sa contreplaque pour optimiser la force de rétention.
- La contreplaque doit être montée "flottante", pour compenser un mauvais alignement de la porte.

Les fils de sécurité

La ventouse électromagnétique subit tout au long de sa vie une accumulation de chocs répétés et de sollicitations aux niveaux des points de fixation sur le dormant, fréquences d'ouvertures/fermetures, (tentatives d'ouverture porte verrouillée et tentatives de vandalisme) ce qui peut générer sa désolidarisation du support au moment de l'ouverture.

Afin de pallier au risque de chute du bloc ventouse, installer les deux fils de sécurité fournis pour garantir la sécurité des utilisateurs (voir schéma).

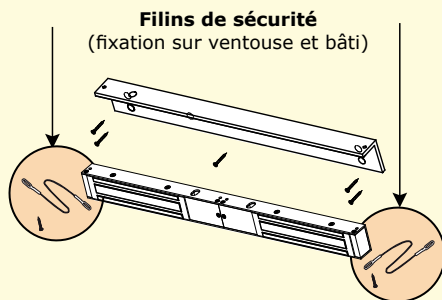















**ENTRETIEN**

La ventouse et sa contreplaque disposent d'un revêtement spécifique qui renforce la protection contre l'usure et la corrosion. Ces produits nécessitent donc peu d'entretien. Néanmoins pour assurer une fonctionnalité optimum, Il est recommandé de nettoyer régulièrement les surfaces en contact de la ventouse et de sa contreplaque avec un chiffon et produits non abrasifs. Si des traces de corrosion venaient à apparaître, il est recommandé de nettoyer et huiler légèrement ces mêmes surfaces en contact. Vérifier et resserrer régulièrement l'ensemble des fixations de la ventouse. Il est nécessaire de mettre un frein-filet sur la vis pivot de la contreplaque.



SD300 - SD300M - SD500 - SD500M

Ventouses électromagnétiques appliques doubles

3] ÉLÉMENTS INCLUS

							
Ventouse saillie	Contre-plaque	Plaque de montage	Goupille 5x16	Rondelle acier	Vis bois 4x25	Clé 3 mm	Clé 5 mm
1	2	1	4	4	14	1	1
							
Vis M8x35	Vis M8x25	Vis auto-foreuse 3x8	Embout de guidage	Ecrou borgne	Filin de sécurité	Rondelle caoutchouc	Notice
2	2	2	2	2	2	2	1

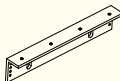
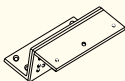
4] ACCESSOIRES EN OPTION

			
Références	LD3LD5	Z3Z4Z5	AMA3 (300 KG) AMA5 (500 KG)
Description	Support en "L" pour ventouse	Support en "Z" pour ventouse	Support de contre-plaque

5] RACCORDEMENT

BORNIER	CORRESPONDANCE	SD300 SD500	SD300M SD500M
+	12 or 24 V DC	■	■
-	- 0 V	■	■
N.C	NC (Normalement fermé)	-	■
COM	COM	-	■
N.O	NO (Normalement ouvert)	-	■



12 V DC
Réglage usine

Le signal NO/NC ne commute que lorsque la porte fermée et sous tension.

SD300 - SD300M - SD500 - SD500M
Ventouses électromagnétiques appliques doubles

AVEC ÉLECTRONIQUE INTÉGRÉE

SD300 - SD500

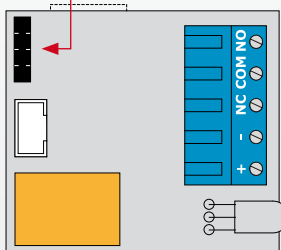
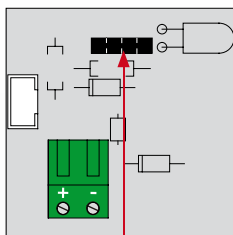

SD300M - SD500M

CONNEXION DIRECTE

12 V DC

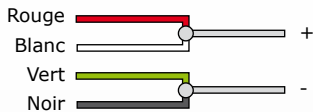

24 V DC

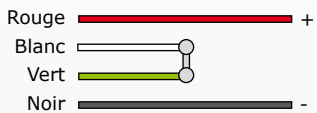

CONTACT



NOTE IMPORTANTE

- Vérifier la position du cavalier avant de brancher la ventouse au courant d'entrée. Une position incorrecte peut endommager la ventouse. Ce type de dommage n'est pas couvert par la garantie.
- La ventouse et la contre-plaque doivent être impérativement alignés.

La contre-plaque doit être montée "flottante" autour de la vis centrale de montage pour compenser un mauvais alignement de la porte.

SD300 - SD300M - SD500 - SD500M
Ventouses électromagnétiques appliques doubles

6] INSTALLATION

Montage sur porte à ouverture extérieure (Poussante)

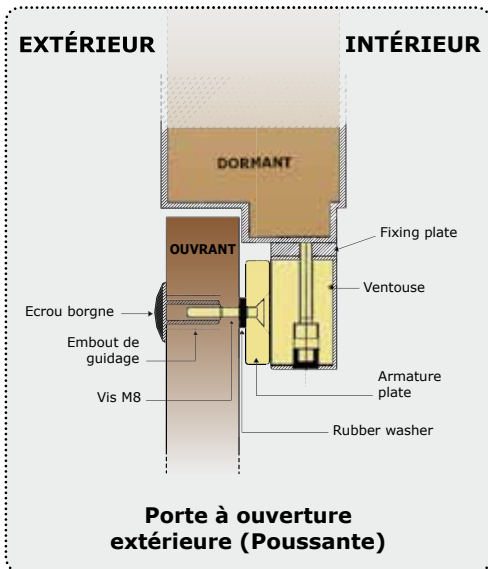
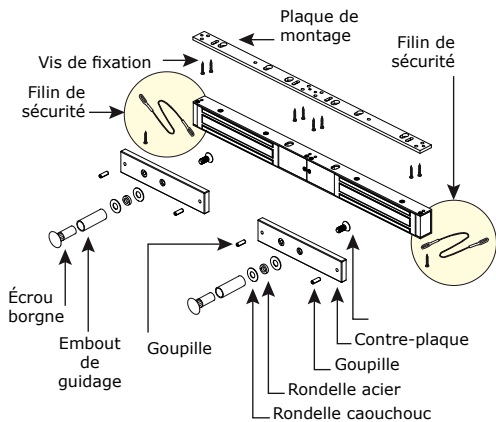

Montage sur porte à ouverture intérieure (tirante)

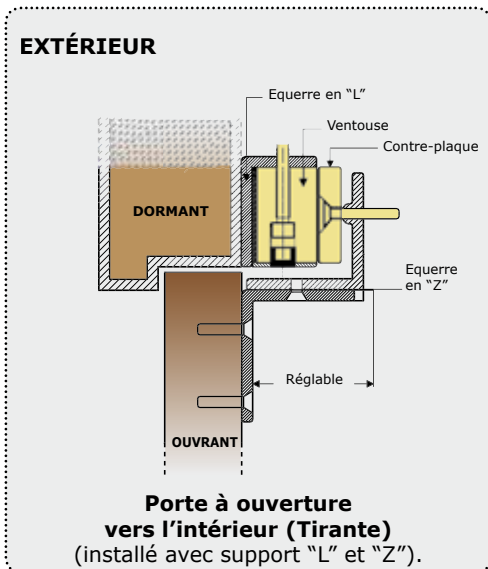
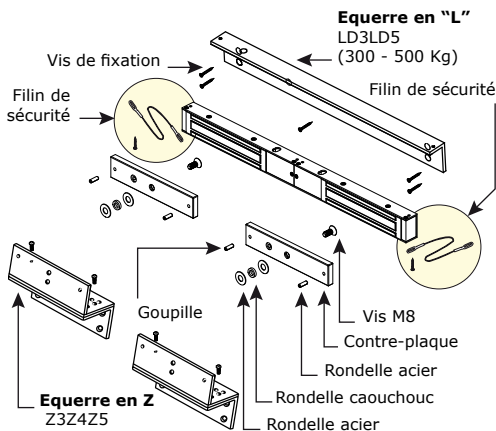

SD300 - SD300M - SD500 - SD500M
Ventouses électromagnétiques appliques doubles

7] INSTALLATION WITH ACCESSORIES

Installation with an Armature housing

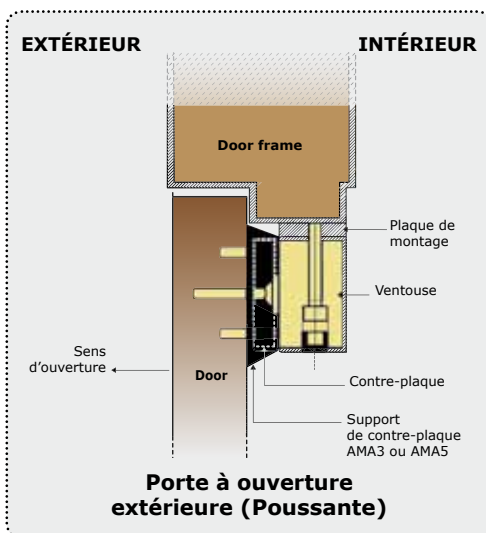
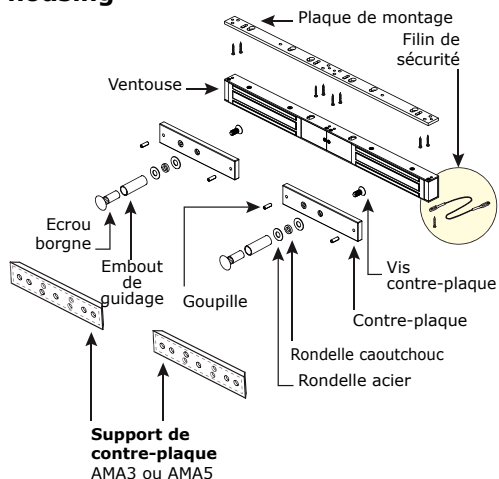

8] DÉPANNAGE

PROBLEMES	CAUSE POSSIBLE	SOLUTIONS
Verrouillage de porte impossible	La ventouse ne reçoit pas de courant CC.	<ul style="list-style-type: none"> - Vérifier que les fils sont bien raccordés au bornier. - Vérifier que l'alimentation est compatible. - Vérifier que la ventouse est reliée correctement au circuit.
Force de maintien réduite	La ventouse et la contre-plaque ne sont pas en vis à vis.	<ul style="list-style-type: none"> - Vérifier que la ventouse est reliée correctement au circuit. - S'assurer que l'électroaimant et la contre-plaque sont bien en vis à vis. - Vérifier que les surfaces de contact sont exemptes de saletés et de rouille. - Vérifier que la contre-plaque est montée souple.
	Tension basse, contre-plaque bridée.	S'assurer que la ventouse est bien alimentée par la tension requise, vérifier le serrage de la contre-plaque et l'état du caoutchouc.
Commutateur Reed HS	Tension trop basse. Mauvais alignement.	<ul style="list-style-type: none"> - Vérifier l'alimentation. - Section de câble à déterminer selon la distance entre l'alimentation et le verrouillage. - ex: $2 \times 1,5\text{mm}^2 \geq 10\text{m}$

SD300 - SD300M - SD500 - SD500M*Ventouses électromagnétiques appliques doubles***9] GARANTIE À VIE [EXTRAIT]***

Les sociétés CDVI garantissent que ce produit est dépourvu de tout vice caché, tant dans les matériaux que dans sa fabrication, à la condition, qu'il soit installé conformément aux préconisations du fabricant et qu'il n'y ait pas eu d'interventions ou de modifications sur le produit. La responsabilité de CDVI se limite à la réparation ou à l'échange du produit. CDVI n'assume aucune responsabilité concernant les dommages sur les biens ou les personnes. Un produit reconnu défectueux par CDVI doit être retourné au service-après-vente de CDVI, après l'obtention du numéro d'autorisation de Retour de Produit(s) Défectueux (RMA). La responsabilité de CDVI se limite à la réparation ou au remplacement d'un produit ou pièces défectueuses, en ses ateliers. L'une ou l'autre de ces interventions sont définis par le service-après-vente de CDVI. Le préjudice imputable à CDVI ne saurait en aucun cas dépasser la valeur du produit. La responsabilité de CDVI ne peut être engagée auprès de l'acheteur, installateur, client final ou qui que ce soit, lors de dommages consécutifs à des imperfections ou mauvais fonctionnement du produit. Cette garantie prend effet à la date d'enregistrement du produit auprès de CDVI, à partir de l'instant ou la date d'enregistrement est dûment complétée, dans la limite d'un mois, après la date de livraison au client final. Pour obtenir les détails complets de cette garantie et enregistrer votre/vos produit(s) pour bénéficier de cette « Garantie à Vie limitée ». Veuillez compléter la carte d'enregistrement présente dans la boîte du produit et nous la retourner, par email ou par courrier, à l'adresse de l'entité CDVI la plus proche ou vous enregistrer en ligne à l'adresse www.cdvigroup.com. Les contacts des entités CDVI sont accessibles en ligne à l'adresse www.cdvigroup.com ou au dos de la notice d'installation.

A L'EXCEPTION DES POINTS EVOQUES PRECEDEMMENT, CDVI N'APPLIQUE AUCUNE GARANTIE, NI DELIBEREE NI TACITE, A TOUS LES PROBLEMES INCLUANT LE CONDITIONNEMENT, LE TRANSPORT, LEUR COMMERCIALISATION OU LES CONDITIONS D'UTILISATIONS PARTICULIÈRES.

10] NOTES

* Voir les conditions de garantie à vie limitée complètes sur le site cdvigroup.com.

Manufacturing Access Control since 1985



CDVI Group

FRANCE (Headquarter/Siège social)
Phone: +33 (0)1 48 91 01 02
Fax: +33 (0)1 48 91 21 21

All the information contained within this document (photos, drawing, features, specifications and dimensions) could be perceptibly different and can be changed without prior notice.
Toutes les informations mentionnées à titre indicatif sur le présent document (photos, dessins, caractéristiques techniques et dimensions) peuvent varier et sont susceptibles de modifications sans notification préalable.

CDVI

FRANCE + EXPORT
Phone: +33 (0)1 48 91 01 02
Fax: +33 (0)1 48 91 21 21

CDVI AMERICAS

[CANADA - USA]
Phone: +1 (450) 682 7945
Fax: +1 (450) 682 9590

CDVI BENELUX

[BELGIUM - NETHERLAND - LUXEMBOURG]
Phone: +32 (0) 56 73 93 00
Fax: +32 (0) 56 73 93 05

CDVI

TAIWAN
Phone: +886 (0)42471 2188
Fax: +886 (0)42471 2131

CDVI

SUISSE
Phone: +41 (0)21 882 18 41
Fax: +41 (0)21 882 18 42

CDVI

CHINA
Phone: +86 (0)10 62414516
Fax: +86 (0)10 62414519

CDVI IBÉRICA

[SPAIN - PORTUGAL]
Phone: +34 (0)935 390 966
Fax: +34 (0)935 390 970

CDVI

ITALIA
Phone: +39 0331 97 38 08
Fax: +39 0331 97 39 70

CDVI

MAROC
Phone: +212 (0)5 22 48 09 40
Fax: +212 (0)5 22 48 34 69

CDVI SWEDEN

[SWEDEN - DANEMARK - NORWAY - FINLAND]
Phone: +46 (0)31 760 19 30
Fax: +46 (0)31 748 09 30

CDVI UK

[UNITED KINGDOM - IRELAND]
Phone: +44 (0)1628 531300
Fax: +44 (0)1628 531003

DIGIT

FRANCE
Phone: +33 (0)1 41 71 06 85
Fax: +33 (0)1 41 71 06 86